

		((
!)))

Over operating free-air temperature unless otherwise noted ⁽¹⁾

DESCRIPTION	MIN	MAX	UNIT
VIN, EN	-0.3	47	V
BST	-0.3	54	V
SW	-1	47	V
SW <10ns	-2.5	49	V
BST-SW	-0.3	7	V
FB	-0.3	6	V
Operating junction temperature ⁽²⁾	-40	150	C
Storage temperature T _{STG}	-65	150	C

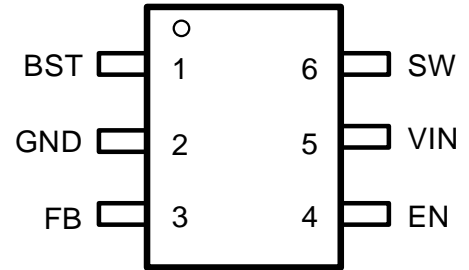

6-Lead Plastic TSOT23-6

(1))))))

(2))))))

		())
))
))
))
))
))
))
))
))

(
)		
		(
		(((
		(((
		(((
		(((
		(((
		(((
(1))
(2))

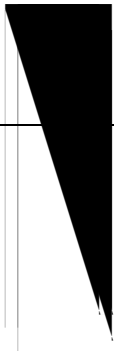

*

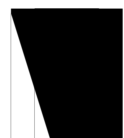

			██████████ ██████████)	
			██████████	
			██████████	
	(██████████ ██████████ ██████████	
			██████████	
	(
		*	██████████	
		*	██████████	
%			██████████	

%

))



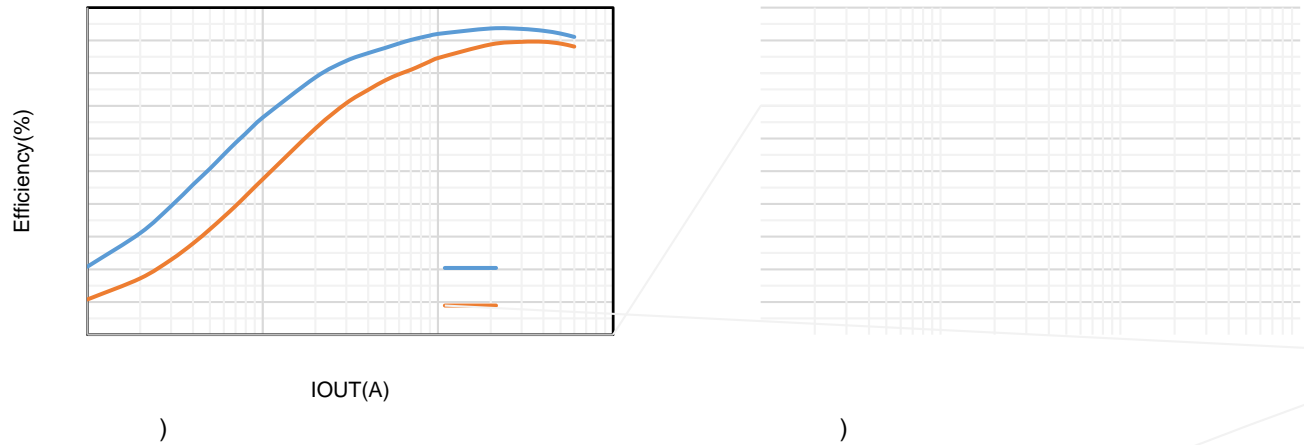

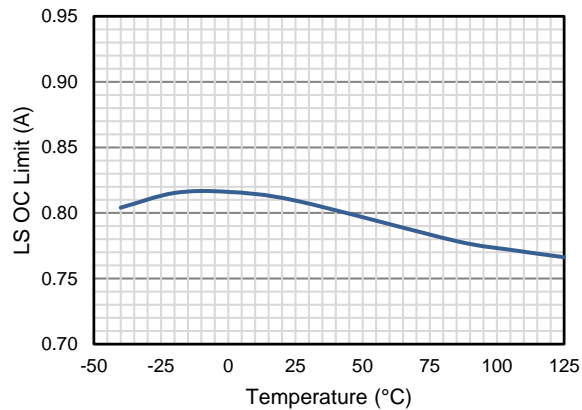

)

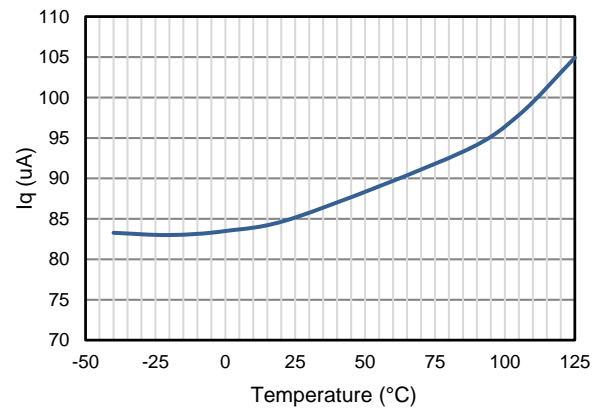

)

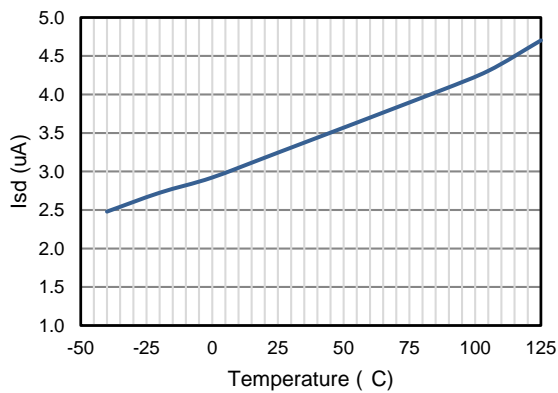

)

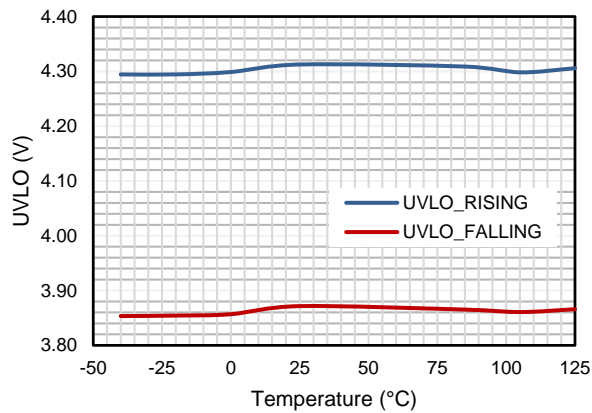
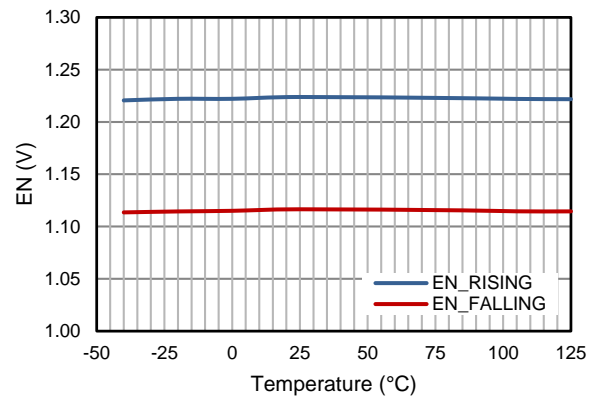

)

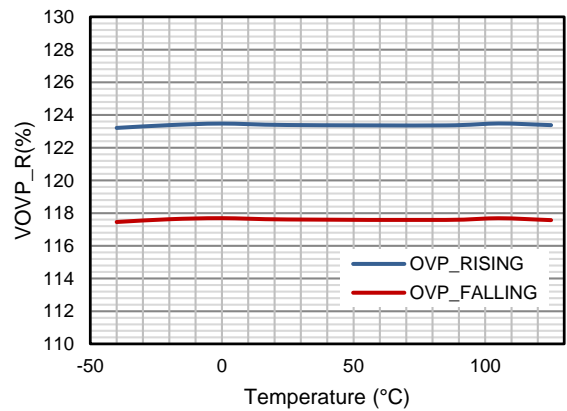

)

))



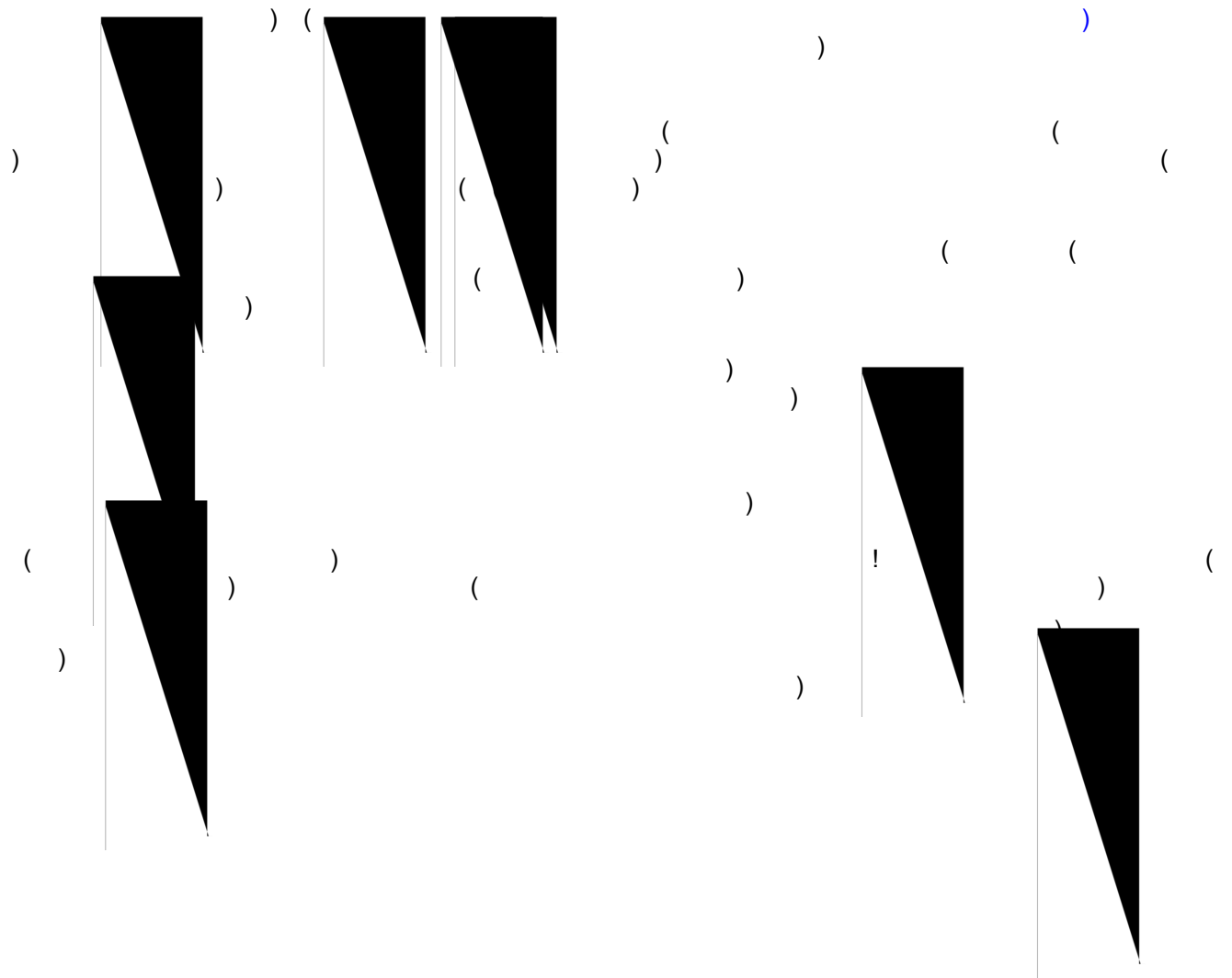

)

)

)

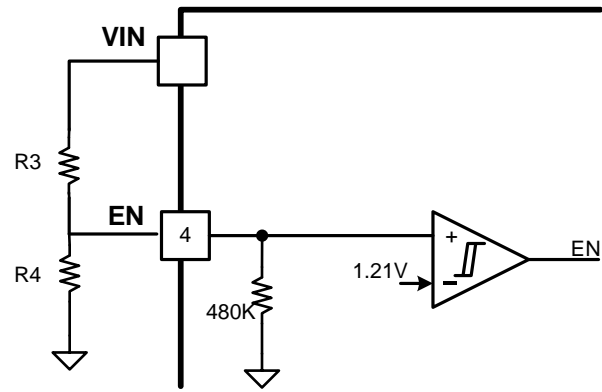

)

(1)

(2)

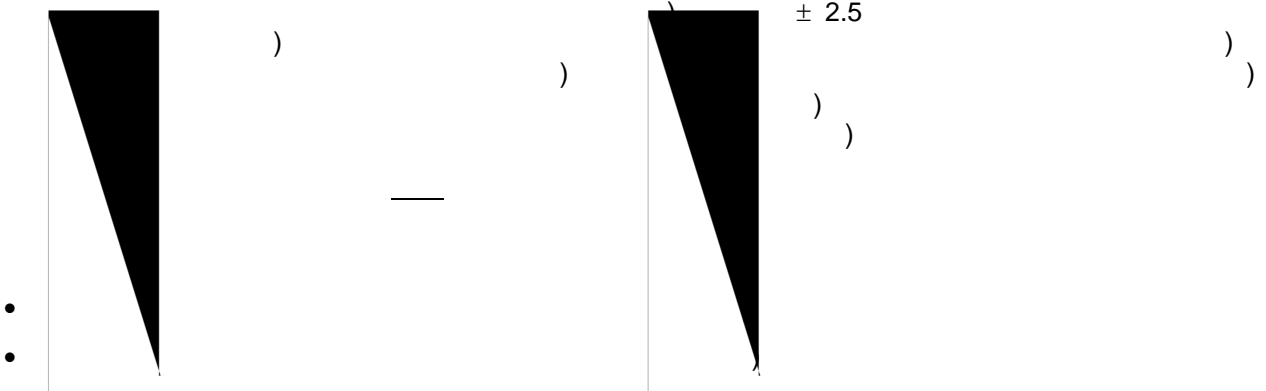

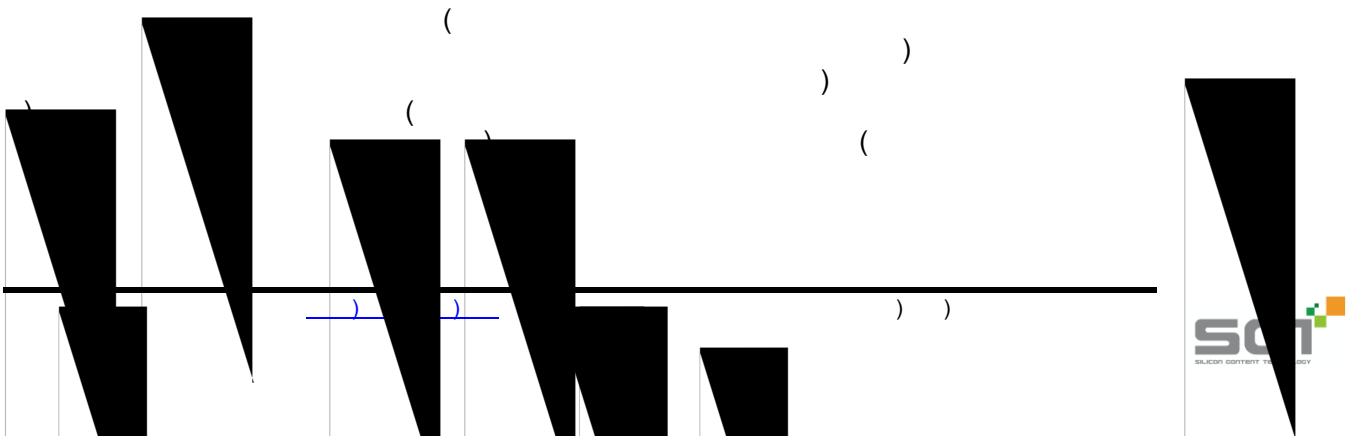
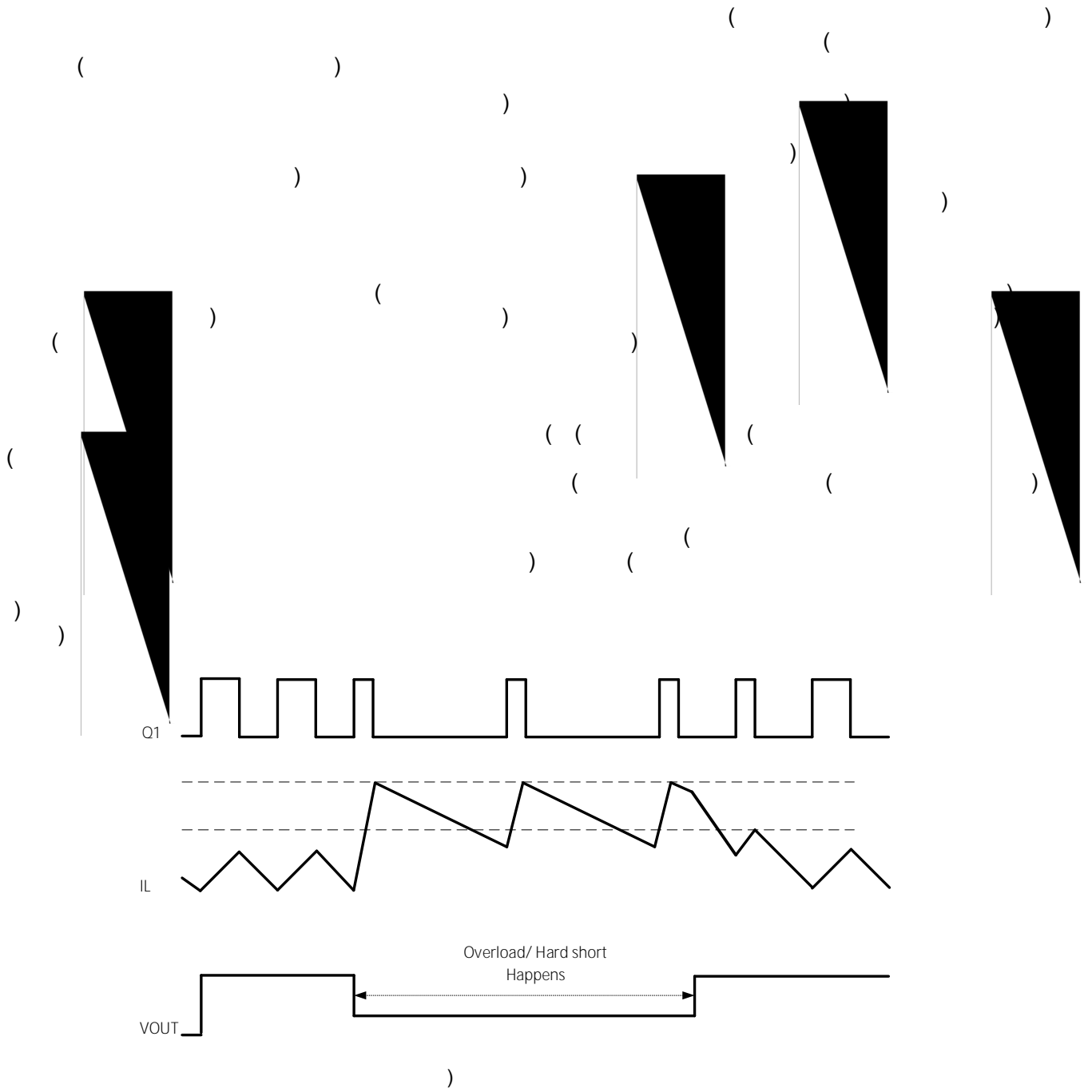

)

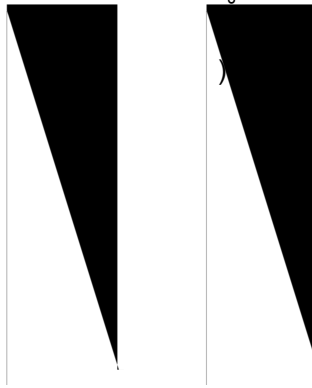

))



))

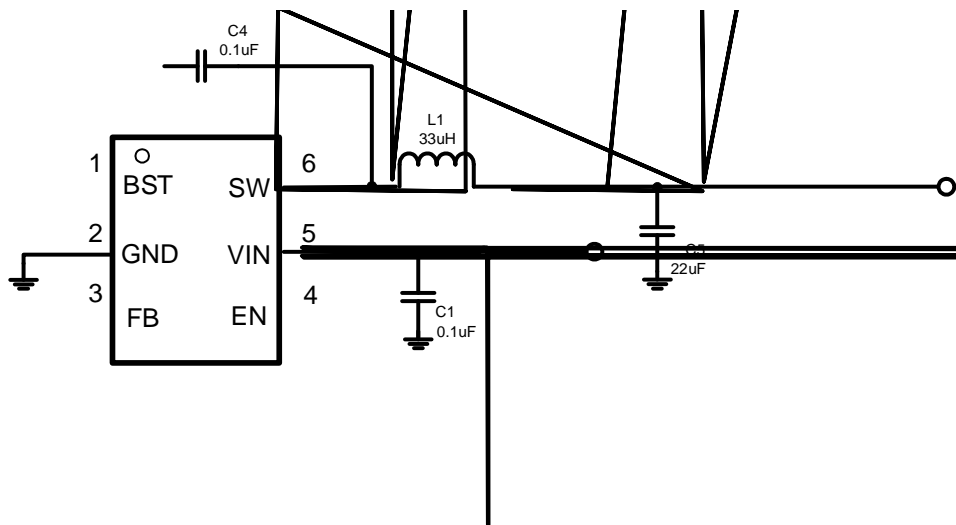
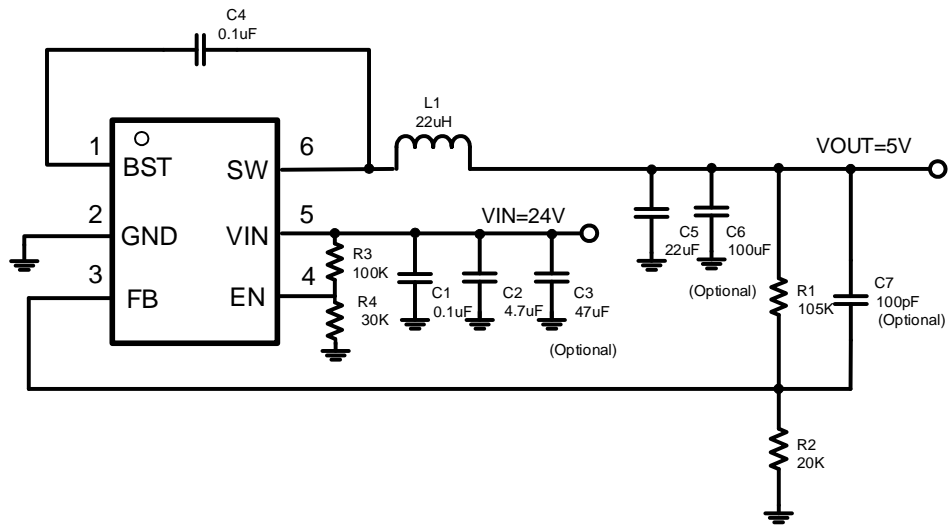

Design Parameters	Example Value
Input Voltage	24V
Output Current	0.6A
Switching Frequency	1.2MHz
Start Input Voltage (rising VIN)	5.5V
Stop Input Voltage (falling VIN)	5V

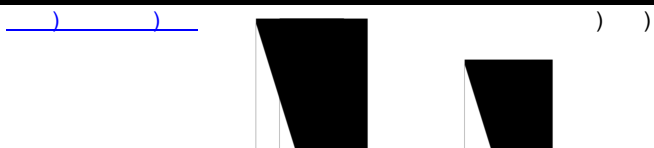
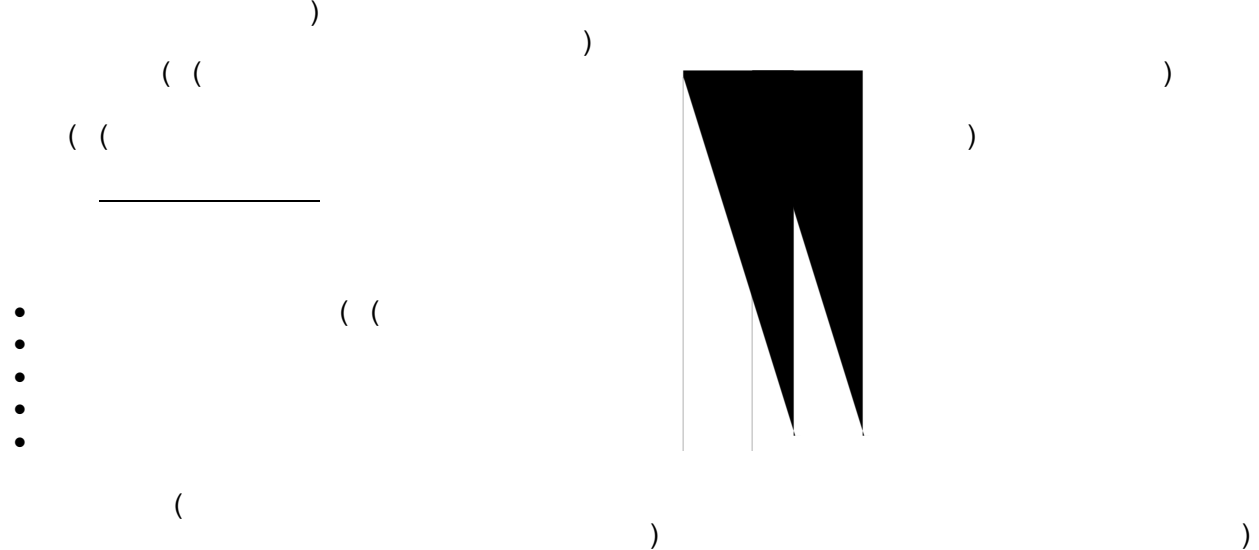
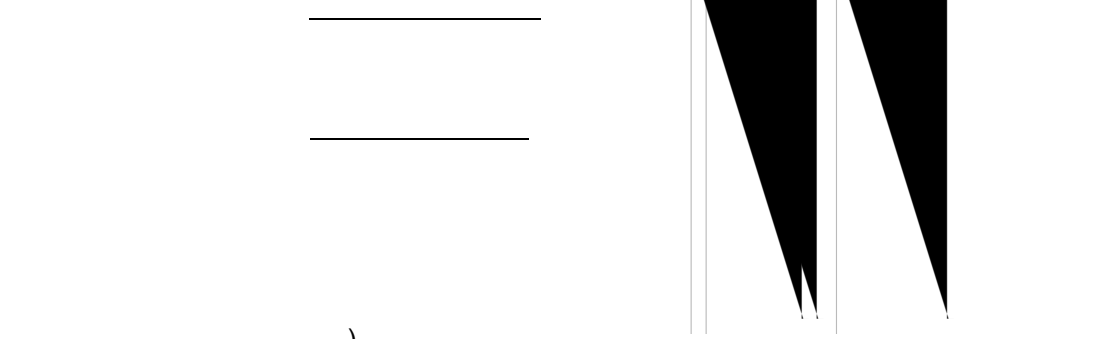
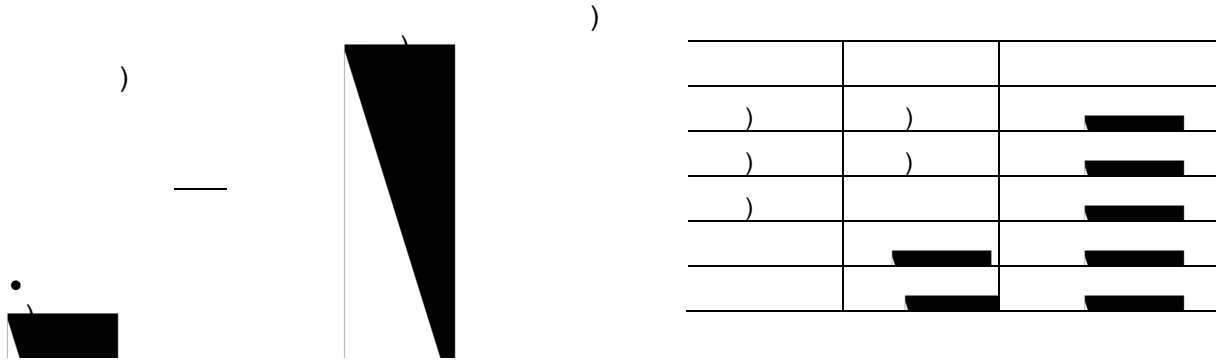

•
•
•
•
•
•

)

)

)

—



•
•
•
•

((

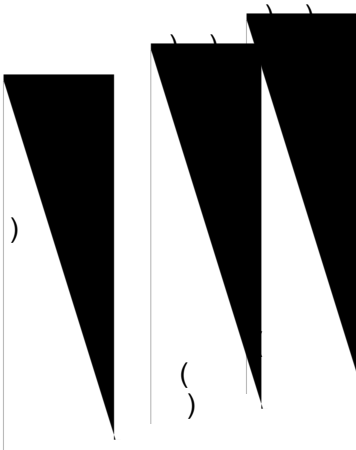

)

)

{
}

)

F D ÷ F D F

%

)

)

)

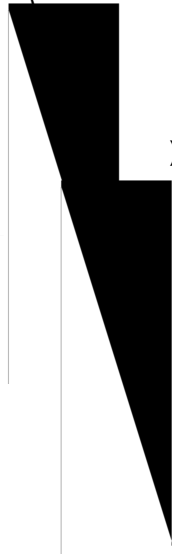

(

)

)

)

)

)

)

)

-
-
-
-
-
-

)

)

)

)

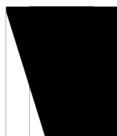

))

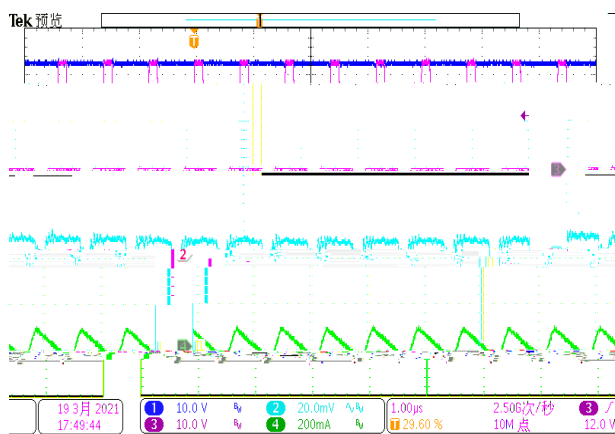
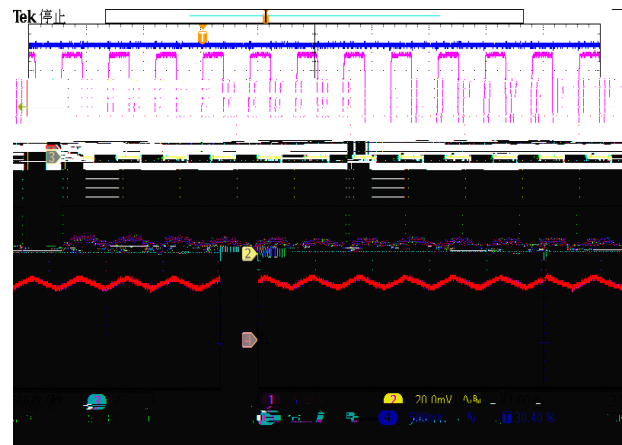
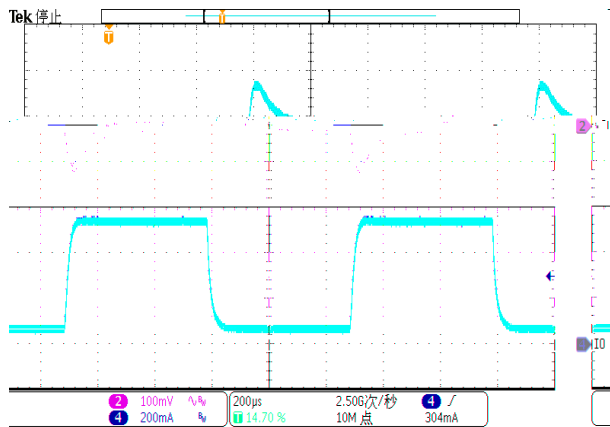
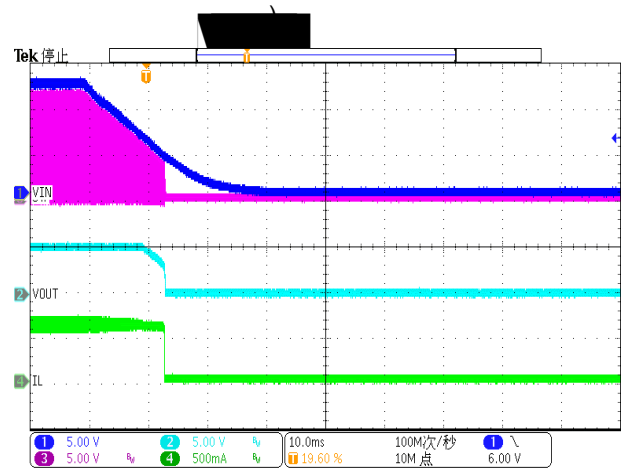
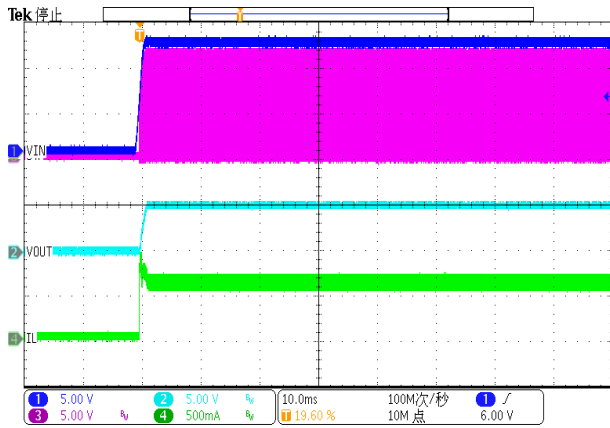

1.) ()
2.))
3.))
4.))

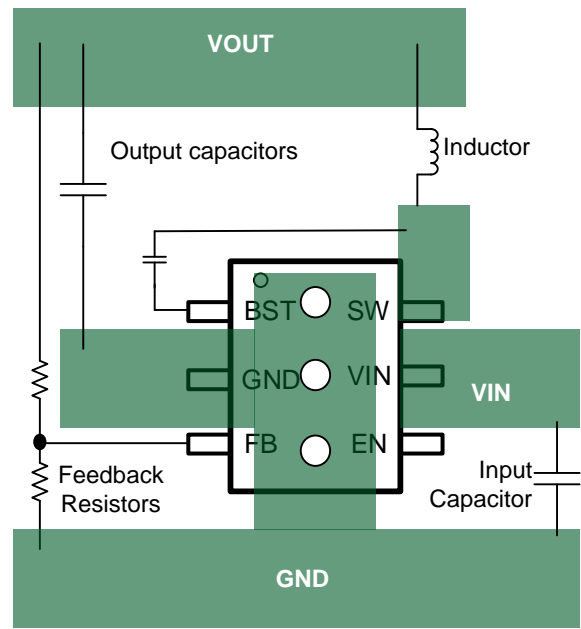

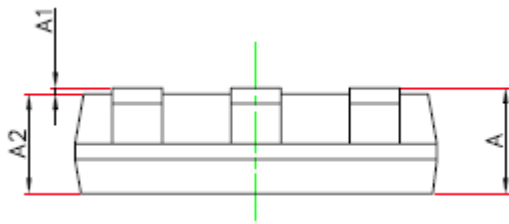
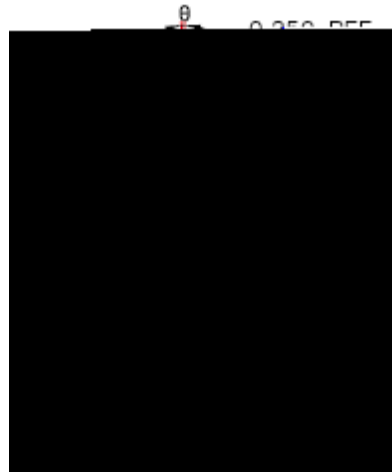
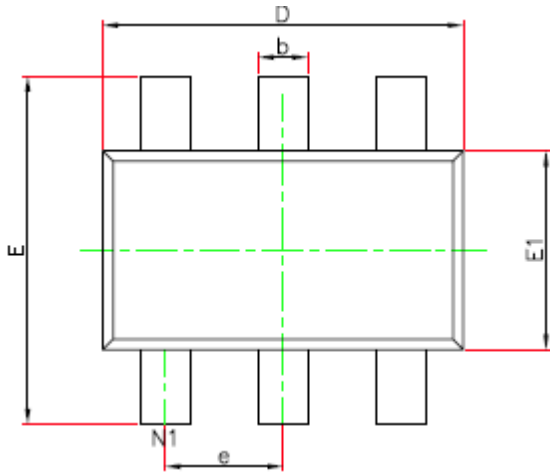

	((()
	▬		▬
	▬		▬
))
))
))
	▬		▬
	▬		▬
	▬		▬
	▬		▬

